

# RALLY / ROAD

## Group G2 - Technical Regulations

### PREAMBLE

These regulations detail the primary vehicle eligibility criteria for the Australian Rally Championship (ARC).

Group G2 caters for two-wheel drive vehicles available on the Australian motor vehicle market. It is intended to produce vehicles which will compete closely against each other and be exciting for TV audiences, spectators and competing crew. Safety provisions shall be of an international standard. Complexity and cost have both been limited to an extent, however this is not the primary aim of this Group.

### 1. INTRODUCTION

These regulations must be read in conjunction with Schedules A and R of the CAMS Manual of Motor Sport, which shall also apply.

Where an issue is not specifically addressed by these regulations, the Production Rally Car (PRC) regulations shall apply.

Where no freedom is provided, or the applicable regulations are silent, then no change to the base car is permitted.

Four engine substitution options exist and different provisions apply to each.

The right to introduce control/specified components is reserved.

In order to detail its specification, the right to require a vehicle to be homologated by CAMS is reserved.

### 2. ELIGIBILITY

- (a) To be eligible for Group G2, the model of automobile shall be:
  - (i) two-wheel drive only (front or rear);
  - (ii) fitted with two or more seats for the occupants;
  - (iii) of closed configuration (open cars/convertibles are not eligible) ;
  - (iv) available for purchase to members of the Australian public through the normal commercial distribution network of the original vehicle manufacturer (or their authorised Australian distributor, as approved by CAMS);
  - (v) certified for road use in Australia and listed on the Road Vehicle Certification System (RVCS) published by the Department of Transport and Regional Services (DOTARS): [http://rvcs-prodweb.dot.gov.au/pls/wwws/pubrvcs.Notify\\_Search](http://rvcs-prodweb.dot.gov.au/pls/wwws/pubrvcs.Notify_Search)
  - (vi) one which was still in production within the last seven (7) years; eg, a model which remained in production through until 2005 would remain eligible for the ARC in 2012. If production of this model did not continue beyond 2005, this model would not be eligible for the ARC from the beginning of 2013.
- (b) Left-hand drive versions of such cars may be used provided they are identical in all respects other than the reversal of the driving position.
- (c) Alternatively, a 4WD ARC Car, PRC, Group N(P) car or FIA Group N homologated car which is converted to 2WD (either front or rear), is eligible for Group G2. Those elements of the drive train related to solely to the non-driven end of the car may be removed.

**Note:** A car which is factory produced in 2WD format must remain in its original front- or rear-wheel drive configuration.

### 3. GENERAL

#### 3.1 Materials: Parts deemed free in these regulations must be in conformity with Article 252-1.3 of FIA Appendix J.

Furthermore, the use of titanium alloy, magnesium alloy and ceramics is prohibited, except for parts mounted on the (series) model.

The use of carbon fibre or Kevlar is authorised on condition that only one layer of fabric is used and is affixed to the visible face of the part.

The side protections of the bodywork and other free parts may be made of several layers of Kevlar or fibreglass.

The fuel tank protections may be made from several layers of Kevlar, carbon fibre or fibreglass.

**3.2 Ground clearance:** Ground clearance is free.

**3.3 General Modifications:** The original mechanical parts necessary for the propulsion and suspension, as well as all accessories necessary for their normal functioning (except any steering or braking parts), having undergone all normal machining operations laid down by the manufacturer for Series Production, they may be subject to all tuning operations through finishing and scraping but not replacement. Provided that the origin of the Series Production part may always be established its shape may be ground balanced, adjusted, reduced or modified through machining.

The modifications defined by the foregoing are permitted only on condition that the weights and dimensions specified in the Recognition Form (FIA Homologation, CAMS Homologation or Recognition Form or manufacturer's published specifications) are respected. Only chemical and heat treatment/s are allowed, in addition to the above.

Damaged threads can be repaired provided they have the same interior diameter.

The limits of the modifications and fittings allowed are specified hereinafter.

## 4. ENGINE

Original/recognised series production engine or approved substitute engine, as follows:

(a) **Option 1:** Refer PRC.

**OR**

(b) **Option 2:** A substitute production based engine built for the purposes of road going use from the vehicle manufacturer (or one of its brands) with:

- four cylinders
- up to 2000cc capacity
- naturally aspirated induction

Direct injection is not permissible unless standard on the substitute engine.

Where a substitute engine is fitted, the engine and kit required for fitment shall be documented in the homologation form.

**OR**

(c) **Option 3:** A substitute engine which is homologated and complies with FIA Group R regulations. Such an engine shall conform in all respects to its homologated specification and the Group R regulations, with the following exceptions which may comply with Group G2:

- exhaust manifold
- oil sump

**OR**

(d) **Option 4:** A substitute 1.6 litre turbocharged/supercharged engine, from the vehicle manufacturer, which is homologated by the FIA for Super 2000 race or rally competition. Such an engine shall conform in all respects to its homologated specification and the Super 2000 regulations, including the use of a inlet restrictor with a maximum internal diameter of 30mm (aligns with regional FIA regulations). All other dimensions detailed in the Super 2000 regulations for the restrictor shall apply. The general freedoms relating to engine modification in these regulations shall not apply to such engines. The competitor is required to present all relevant FIA homologation information upon request of ARC officials.

**4.1 Cylinder capacities:** Refer to PRC regulations.

### 4.2 Engine mounting:

**General:** Engine mounting bushes are free except that the number and location of the engine mountings originally fitted to the engine that is being utilised shall remain unchanged.

No modifications may be made to any bodywork to accommodate an engine or a gearbox, save for the drilling of holes to support components, or to facilitate the fitting of the gear change mechanism.

**Option 2, 3 & 4:** The mounting and location of the replacement engine shall comply with the following:

- It shall be mounted in the same general location as the original.
- The crankshaft rotational axis shall be moved no more than 25mm in relation to that of the original engine. If it is not possible to fit a replacement engine in accordance with this criteria, an application may be made for an exemption to the Australian Rally Commission. Such an approval shall be detailed in a CAMS homologation form.
- The engine may be moved freely along the crankshaft axis to adjust to the transmission.
- The inclination of the substitute engine shall be the same as its original application, plus or minus 25° to the vertical. This shall be measured in relation to the centreline of the bore.

**4.3 Complete pistons:** Refer to PRC regulations.

### 4.4 Connecting rods:

**Option 1 & 2:** The connecting rods are free, provided they are manufactured of steel.

**Option 3 & 4:** Refer to FIA regulations/homologation.

### 4.5 Crankshaft:

**General:**

The crankshaft is free provided it is manufactured from the standard material or steel. The crankshaft may receive chemical or heat treatment different to that laid down for the Series Production parts.

**Option 3 & 4:** Refer to FIA regulations/homologation.

#### 4.6 Engine flywheel:

- (a) **Option 1 & 2:** The engine flywheel may be replaced subject to it complying with the following conditions:
- the minimum weight is 4kg with fixing screws;
  - the starter ring must be integrated with the engine flywheel and if a separate component, the starter ring shall be attached by welding;
  - the minimum diameter is 250mm;
  - it shall be made of steel.
- (b) **Option 3 & 4:** Refer to FIA regulations/homologation.

#### 4.7 Cylinder head:

**General:** The following modifications are authorised:

1. Machining of camshaft passages.
2. The cylinder head port sizes and shape may be modified by the removal of metal only.
3. It is authorised to completely close unused openings in the head, if the only function of that operation is complete closure.
4. The inlet and exhaust valve sizes and valve seats are free. The minimum modifications required to fit these items are permitted.

**Option 2:** Variable valve /camshaft timing is not permitted in any form. If an engine was originally fitted with such a system, it shall be disabled and may be removed.

**Option 3 & 4:** Refer to FIA regulations/homologation.

#### 4.8 Camshaft:

**Option 1 & 2:** The camshaft/s is free save that the maximum valve lift is 12.0mm.

**Option 3 & 4:** Refer to FIA regulations/homologation.

#### 4.9 Tappets/Rocker arms: Tappets/lifters are free save that the replacement units must be interchangeable with the original ones.

Rockers and oscillating levers are free provided they are interchangeable with the originals.

The valve spring retainers, cotters and guides, even if not included as original equipment, are free. Valve buckets and shims are free.

**Option 3 & 4:** Refer to FIA regulations/homologation.

#### 4.10 Intake manifold:

**Option 1, Turbo/Supercharged:** The original manifold shall be retained.

**Option 1 Naturally Aspirated, Option 2:** Free, save that variable geometry is prohibited.

**Option 3 & 4:** Refer to FIA regulations/homologation.

#### 4.11 Throttle valve housing:

**Option 1, Turbo/Supercharged:** The original throttle valve housing shall be retained.

**Option 1 Naturally Aspirated, Option 2:** Free, save that only one throttle valve per cylinder is permitted and that variable geometry is prohibited.

**Option 3 & 4:** Refer to FIA regulations/homologation.

#### 4.12 Throttle valve (eg, butterfly, barrel):

**Option 1:** If the series vehicle is equipped with a motorised throttle valve, a mechanical throttle valve kit may be fitted and vice versa, respecting the maximum diameter of the throttle valve fitted to the series production car.

**Option 2:** A mechanical throttle valve kit shall be fitted.

**Option 3 & 4:** Refer to FIA regulations/homologation.

#### 4.13 Cylinder head gasket: Refer to PRC regulations.

#### 4.14 Balancing Shafts: If the original engine was fitted with balancing shafts, these may be removed together with their drives.

#### 4.15 Engine water cooling: Refer to PRC regulations.

#### 4.16 Oil sump:

**General:**

The oil sump shall meet the following requirements:

- the oil sump must be either made from steel sheet or aluminium. Its sole function must be that of containing oil;
- the number of mounting points must not exceed the original;
- For the sole purpose of fixing an oil deflector, it is permitted to create a maximum of four threaded holes (having a maximum diameter of M5 and maximum depth of 20mm) in the bottom of the cylinder block.

**Option 1:** Free, subject to a wet sump system being employed, unless the vehicle was originally fitted with a dry sump system.

**Option 2, 3 & 4:** Free, subject to a wet sump system being employed.

#### 4.17 Oil pressure accumulator: Free, subject to a maximum capacity of three litres.

#### 4.18 Lubrication system: Refer to PRC regulations.

#### 4.19 Injection system:

**General:** The injection wiring looms are free.

The injection system may be replaced, however direct injection is not permitted as a replacement.  
Fuel pressure shall not exceed 5.5bar or, if direct injection is used, no greater than the original pressure.

## 5. ELECTRICAL EQUIPMENT

**5.1 ECU:** The ECU is free.

**5.2 Rev limit:** 8500rpm maximum.

**Note:** An engine rpm monitor/logger or an ECU which is homologated with a fixed rev limit may be required.

**5.3 Data logging:** Data logging is free.

**5.4 Sensors and Actuators:** Sensors and actuators are free.

**5.5 Electric cable assembly:** Refer to PRC regulations.

**5.6 Battery and location:**

- (a) The make and capacity of the battery/ies is/are free.
- (b) Each battery must be securely fixed and covered to avoid any short-circuiting or leaks.
- (c) The number of batteries laid down by the manufacturer must be retained.
- (d) Should the battery be moved from its original position, it must be attached to the body using a metal seat and two metal clamps with an insulating covering, fixed to the floor by bolts and nuts.
- (e) For attaching these clamps, bolts with a diameter of at least 10mm must be used, and under each bolt, a counterplate at least 3mm thick and with a surface of at least 20cm<sup>2</sup> beneath the metal of the bodywork.
- (f) A wet battery must be covered by a leak proof plastic box, attached independently of the battery.
- (g) Its location is free, however if in the cockpit it will only be possible behind the front seats.
- (h) In this case, and if it is a wet battery, the protection box must include an air intake with its exit outside the cockpit (see Drawings 255-10 and 255-11).
- (i) If the battery situated in the cockpit is a dry battery, it must be protected electrically by a cover which covers it completely.



**Drawing 255-10**

**Drawing 255-11**

Please refer to CAMS in relation to provisions for a Hybrid electrical system.

**5.7 Alternator / Generator / Starter:** Refer to PRC regulations.

**5.8 Isolation Switch:** Each car shall be equipped with a battery isolation (master) switch which isolates the battery and stops the engine. It shall be capable of being operated by the driver in his normal seated position. There must be a second switch, or a remote means of operating the main switch, from the vicinity of the base of the A pillar on the driver's side or, for an automobile with no A pillar, in a comparable position. This external device shall be clearly marked by a symbol showing a red spark in a white-edged blue triangle of minimum edge length 150mm.

## 6. EXHAUST

**6.1 General:** The exhaust after the manifold is free subject to the following requirements:

- (a) It shall incorporate a catalytic converter which is either homologated by the FIA (refer Technical List No 8) and/or is authorised for use on public roads in Australia.
- (b) It may not project in any way beyond the coachwork (in plan);
- (c) The exhaust system must not be provisional;
- (d) Exhaust gases may only exit from the end of the system which must be within 100mm of the perimeter of the car and aft of a vertical plane passing through the centre of the wheelbase;
- (e) The thickness of the tubes used for the exhaust system must be greater than or equal to 0.9mm, measured in the uncurved parts.
- (f) Parts of the chassis must not be used to evacuate exhaust gases;
- (g) Adequate protection shall be provided to prevent heated exhaust pipes from causing burns;
- (h) It shall comply with any specific local requirements.
- (i) On cars fitted with turbocharged engines, the exhaust system is free only after the turbocharger wastegate unit. On such cars heat shields may be fitted to the exhaust manifold and/or the turbocharger for the sole function of heat protection.
- (j) Each device for recycling the exhaust gases or equivalent systems (eg, an additional air pump, active carbon filters) may be removed and the openings resulting from that operation sealed.
- (k) Each car must comply with the CAMS noise level requirements for rally cars.

## 6.2 Exhaust manifold:

**Option 1, 2 & 3:** Exhaust manifold is free.

**Option 4:** Refer to FIA regulations/homologation.

## 7. FUEL SYSTEM AND FUEL

### Fuel tank, pumps and circuit:

- (a) The fuel tank shall be the original series production item, or shall be replaced with an FIA FT3 1999, FT3.5 or FT5 specification fuel tank.
- (b) A replacement fuel tank shall be placed inside the luggage compartment or in the original location.
- (c) The construction of collector tanks with a capacity of less than one litre is free.
- (d) The fuel pump/s is free, but may not be fitted in the cockpit save that if this is an original fitting, the pump/s may remain in place but must be well protected.
- (e) A petrol filter with a maximum capacity of 0.5 litres may be added to the fuel inlet pipe.
- (f) Fuel lines may be replaced, the route of which is free. If a fuel line is replaced, it shall be of an aviation type and comply with Article 13(ii) of Schedule R – “General Requirements for all Rally Cars”.
- (g) It is authorised to drill two holes (maximum diameter of 60mm or equivalent area) in the floor, the sole function of which will be to allow the passage of the lines necessary to feed/empty the fuel tank.
- (h) For cars with a fuel tank installed in the luggage compartment, a fireproof and liquid-proof case must surround the fuel tank and its filler holes. The filler holes shall not be located in the window panels.
- (i) Each car fitted with a fuel tank with filler neck passing through the cockpit must be equipped with a non-return valve homologated by the FIA. This valve, of the type “with one or two flaps”, must be installed in the filler neck on the tank side. The filler neck is defined as being the means used to connect the fuel filler hole of the vehicle to the fuel tank itself.
- (j) On cars on which the fuel tank is in the passenger compartment or the luggage compartment, the fuel filler must be fitted so that spilled fuel will drain away safely to the outside of the car.

The total capacity of the tanks must not exceed that of the series production capacity, or if the car is fitted with an FT3 1999, FT3.5 or FT5 tank, the total capacity of the tanks must not exceed the following limits, in relation to the engine capacity:

up to 700cc	60 Litres
701cc to 1000cc	70 Litres
1001cc to 1400cc	80 Litres
1401cc to 1600cc	90 Litres
1601cc to 2000cc	100 Litres
2001cc to 2500cc	110 Litres
cars over 2500cc	120 Litres

**Fuel:** Any ARC control fuel may be used.

## 8. CLUTCH

The clutch shall meet the following requirements, but is otherwise free:

- (a) the minimum diameter is 183mm;
- (b) it shall have a maximum of two friction discs;
- (c) it shall not incorporate carbon fibre; eg, a cerametallic type clutch is permissible.

**Clutch control:** The type of operation of the clutch is free (eg, hydraulic or cable), provided that the driver actuates it in the same manner as the original (eg, foot pedal).

## 9. GEARBOX/TRANSMISSION

**9.1 Gearbox:** The gearbox shall:

- (a) be original and unmodified; or
- (b) meet the following requirements:
  - (i) it may be shifted sequentially or classically (grid pattern);
  - (ii) have a maximum of six forward ratios plus reverse gear; and
  - (iii) have an aluminium sump and case.

The gearbox is otherwise free.

**9.2 Gearbox mounting:** The gearbox mount/s are free.

**9.3 Gearbox control linkage:** The gearbox shall be manually operated via cable and/or shift rods only, unless the original control mechanism is utilised.

**9.4 Gearbox cooling:** Refer to PRC regulations.

## IO. DRIVELINE

- 10.1 Final drive:** The final drive ratio is free.
- 10.2 Differential:** A mechanical type limited slip differential may replace the original. The differential housing is free.
- 10.3 Propeller Shafts, Half Shafts, Drive Shafts, Axles and Joints:** Refer PRC.

## II. SUSPENSION

### 11.1 Front and Rear Upper Plate:

- (a) The top damper mounting plates of MacPherson type struts are free save that the mounting point on the bodywork shall remain unchanged, save for the permitted strengthening.
- (b) The front suspension mounting points on the body/chassis must be unmodified, save for the permitted strengthening, and be retained and utilised exclusively to mount the suspension components.
- (c) The upper rear suspension mounting points on the body/chassis may be raised vertically by up to 20mm (Dimension H) using sheet metal. The revised suspension mount must remain concentric with the original and shall be used to exclusively mount the suspension components.

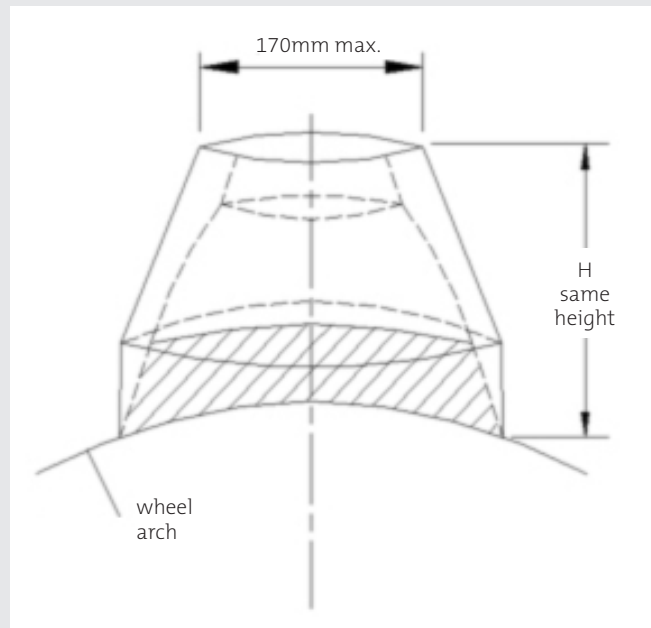

- (d) Strengthening of the suspension mounting points is permitted provided that the material used follows the original shape and is in contact with it. Reinforcements from composite materials are allowed, irrespective of their thickness, provided they are in accordance with this regulation.

**11.2 Front and Rear hubs:** Front and rear hubs are free.

**11.3 Front and Rear Hub carriers:** Front and rear hub carriers are free.

**11.4 Wishbones, trailing arms and strut Front and Rear:** Provided the suspension operation type/method remains the same as the original, each wishbone, trailing arm and strut is free.

**11.5 Replacement Front and Rear Subframes:** A replacement front and/or rear subframe may be fitted subject to the following conditions:

- (a) The replacement subframe must be made entirely of steel;
- (b) the minimum section of the primary members of the replacement subframe must be  $\varnothing$  40mm x 2.0mm or 50mm x 1.5mm.
- (c) the replacement subframe must only be mounted to the chassis by the original subframe mounting points;
- (d) no modification to the original chassis to fit the replacement subframe is permitted.

The design of any replacement subframe is otherwise free, including the location of any suspension mounting/pivot points.

**11.6 Front and Rear Anti-Roll Bars:** The anti-roll bars must be made from ferrous material and must not be adjustable from the cockpit, but are otherwise free, as are their anchorage points. These points may be used for the mounting of reinforcement bars but must not have any other function.

**11.7 Front and Rear Shock absorbers:** Refer to PRC regulations.

**11.8 McPherson type shock absorbers:** The strut body containing the damping element is free, provided the suspensions system continues to operate on the identical principle.

**11.9 Track:** In vertical projection, the bodywork must cover at least 120° of the upper part of the wheels (situated above the axis of the wheel when seen from the side).

## 12. BRAKES

- 12.1 Braking system and circuit:** Refer to PRC regulations.
- 12.2 Pedal box:** The pedal box is free.
- 12.3 Master Cylinder:** The master cylinder is free.
- 12.4 Master Vac/Servo-brake:** The master vac/servo-brake is free.
- 12.5 Regulator/front to rear bias adjustment:** The regulator/front to rear bias adjustment is free.
- 12.6 Handbrake:** Refer to PRC regulations.
- 12.7 Front Calipers:** The front calipers are free provided they have a maximum of four pistons per caliper. If the original car had more pistons than that number shall be the maximum for that car.
- 12.8 Front Discs:** The front discs are free subject to the following:
- the discs shall be sourced from a large scale production catalogue or from a competition parts catalogue;
  - are made from ferrous metal;
  - the maximum diameter of each disc is 330mm for asphalt and 305mm for gravel;
  - if the original car had larger discs then that diameter shall be the maximum for that car;
  - a device to protect the brake discs from flying stones is permitted.
- 12.9 Rear Calipers:** The rear calipers are free provided they have a maximum of four pistons per caliper. If the original car had more pistons than that number shall be the maximum for that car.
- 12.10 Rear Discs:** The rear discs are free subject to the following:
- the discs shall be sourced from a large scale production catalogue or from a competition parts catalogue;
  - are made from ferrous metal;
  - the maximum diameter of each disc is 300mm;
  - if the original car had larger discs then that diameter shall be the maximum for that car;
  - a device to protect the brake discs from flying stones is permitted.

## 13. STEERING

- 13.1 Steering, rods and column:** The original steering type shall be retained (eg, rack and pinion, recirculating ball etc), however freedom is provided in relation to the following items:
- power steering system (modification, addition or deletion);
  - steering ratios, which must be commercially available;
  - steering arms, dampers, column and rack;
  - the steering rack and steering ratio. If a new steering rack is fitted, it will be possible to modify the bodysell the minimum amount necessary for the passage of the steering column;
  - the steering column as well as its mounting systems, provided the steering column is fitted with a shock-absorbing/collapsing system;
  - steering rods and joints and their connecting parts are free provided they are made from ferrous material.
- 13.2 Steering tank:** The power steering fluid reservoir is free.

## 14. WHEELS AND TYRES

The wheels must be made from cast aluminium or steel.

Wheel fixations by bolts may be freely changed to fixations by pins and nuts.

The use of track spacers is freely authorised.

The use of any device for maintaining the full performance of the tyre with an internal pressure equal to or less than the atmospheric pressure is forbidden. The interior of the tyre (space between the rim and the internal part of the tyre) must be filled only with air.

Maximum diameter of the complete wheel: 650mm.

The diameter of the rims is free.

In no case may the width of the rim in relation to the swept volume of the engine, exceed the following:

Up to 1000cc	6.5"	2000cc	8.5"
1400cc	7.0"	5000cc	9.0"
1600cc	7.5"	over 5000 cc	10.0"

Wheel embellishers must be removed.

For gravel rallies, the minimum weight of each rim (wheel excluding tyre and valve) is 8.6kg.

For asphalt rallies, the minimum weight of each rim (wheel excluding tyre and valve) is 8.9kg.

## 15. BODY/COACHWORK

- 15.1 Front doors/Front side windows:** It is permissible to install foam to protect against lateral collisions, provided the installation complies with the following:
- Minimum volume of foam: 60L (see document titled "Specification for 2011 Door foam" in the Homologation Regulations for Super 2000 Kit Variants (Rallies) / WRC).
  - For this purpose, it is obligatory to use the following elements:

- (i) Modification of the interior part of the door.
- (ii) Polycarbonate side windows (minimum thickness 4mm +0/-0.20mm). It must be possible for these windows to be removed without the use of tools.
- (iii) Door trims (six-ply of carbon or carbon-Kevlar).

If foam and the above elements are homologated, their use is compulsory.

**15.2 Sunroof/Roof Hatch/Vent:** Refer to PRC regulations.

**15.3 Windscreen:** Refer to PRC regulations.

**15.4 Body Kit Components:** Refer to PRC regulations.

It is permitted to replace the following original/homologated body kit components with a replica of the original/homologated item:

- front 'lip' spoiler;
- bumper bar/air dam assembly (front and rear);
- side skirt;
- rear wing/spoiler.

The material from which the replacement body kit component is made is free.

**15.5 Front bumper:** In addition to Article 71, the front bumper may be modified as follows:

- it may have additions made to mould, join or align with the permitted flares;
- a lip spoiler in accordance with the following diagram may be added:

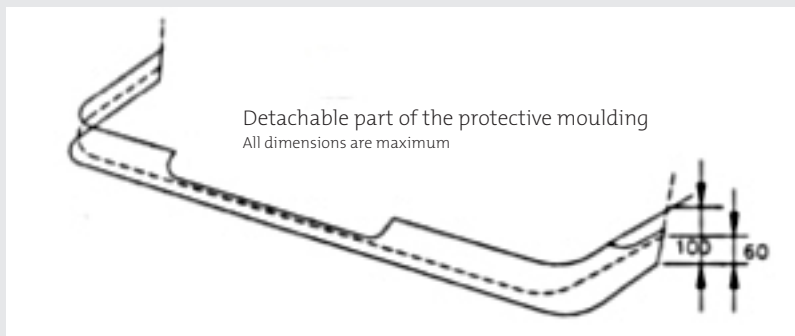

**15.6 Rear bumper:** In addition to Article 71, the rear bumper may be modified as follows:

- It may have additions made to mould, join or align with the permitted flares;
- The original cut-out of the rear bumper for the exhaust may be enlarged; or a circular opening with a maximum diameter of 10cm or an equivalent section created.

**15.7 Flares:** It is permitted to add wheel arch flares by integrating the flare with the guard or bodywork or by bolt-on means, provided that the increase in the total width of the bodywork at the flare is less than 140mm and that the flare does not exceed the radius of the original wheel arch opening by more than 200mm (refer to Drawing).

For the purpose of wheel and tyre clearance, it is permitted to remove up to 75mm of original bodywork measured radially from the edge of the original wheel arch outwards. Any cavity exposed in a door or wheel arch through the removal of metal must be covered by the addition of a metal closing panel. Any body joint protrusions must be rendered safe. The operation of any door must not be affected.

Alternatively, a guard which is attached by bolts may be replaced with another which incorporates the permitted flare and complies with the specifications detailed above. The material from which the replacement guard is made is free.

*continued ...*

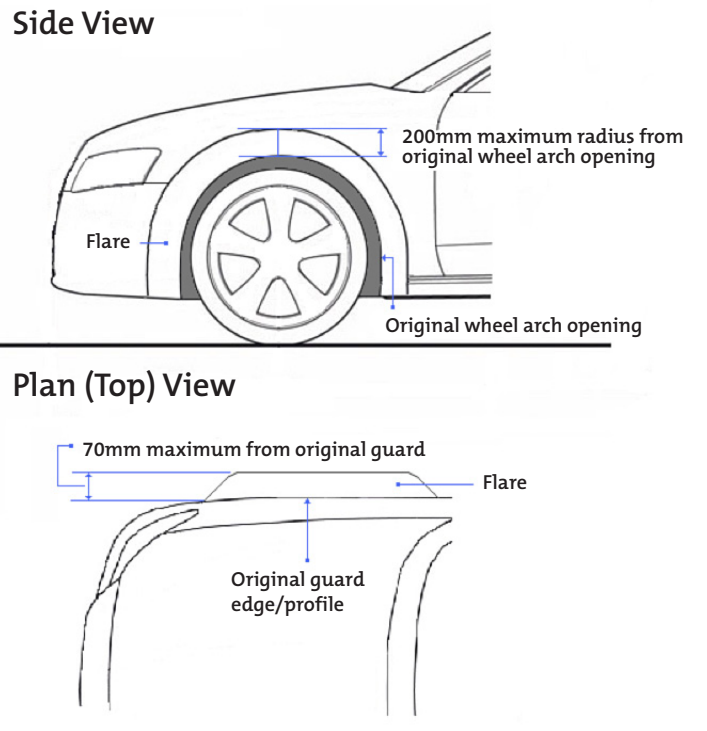

## 16. SAFETY CAGE

The minimum configuration of the safety cage shall be in accordance with the current requirements for rallies in FIA Appendix J, Article 253-8. Schedule J shall otherwise apply.

A CAMS-certified safety cage shall also be acceptable.

## 17. INTERIOR

**17.1 Seats:** The seats provided for the occupants shall be homologated by the FIA to the 8855/1999 or 8862/2009 standard.

In the case of seats to the 8862/2009 standard, homologated seat mounts must be used.

For seats to the 8855/1999 standard, the mountings shall comply with FIA Appendix J, Article 253-16, unless original.

**17.2 Dashboard:** The material of the dashboard is free, but the general shape and the appearance of the original model must remain unchanged.

The dashboard hump(s) may be modified. The height of the dashboard humps may be reduced by a maximum of 50mm over a maximum width of 400mm. The resulting opening must be closed.

The minimum weight of the bare dashboard is 4kg.

The anchorage points may be modified for the sole purpose of installing the safety cage.

The trimmings below the dashboard, and which are not part of it, may be removed.

It is permitted to remove the centre console so long as it does not hold any heating controls or instruments (as shown in the following drawing).

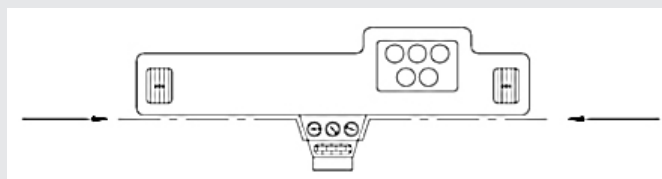

**17.3 Air Conditioning System:** Refer to PRC regulations.

**17.4 Harnesses:** A Type A harness as detailed in Schedule I shall be fitted for each crew member.

Two belt/webbing cutters must be carried on board at all times. They must be easily accessible by the driver and co-driver when seated with their harnesses fastened.

**17.5 Fire Extinguisher:** Refer to Schedule H in the CAMS Manual of Motor Sport.

In addition to the specified hand held fire extinguisher/s, a plumbed in system homologated by the FIA is mandatory. Refer Technical List no. 16: "Extinguisher systems homologated by the FIA".

The driver must be able to trigger the plumbed in extinguisher/s manually when seated normally with the safety belts fastened and the steering wheel in place.

Furthermore, a means of triggering from the outside must be combined with the circuit-breaker switch. It must be marked with a letter "E" in red inside a white circle of at least 10cm diameter with a red edge.

**17.6 Frontal Head Restraints:** A Frontal Head Restraint (FHR) is mandatory for each competing crew member in a Group G2 vehicle – refer Schedule D, Article 3.2, type A.

## 18. WEIGHT

The minimum weight of the car shall be as follows:

Capacity	FWD	RWD
Up to 1000cc	760kg	720kg
1001cc to 1150cc	830kg	790kg
1151cc to 1400cc	880kg	840kg
1401cc to 1800cc	970kg	920kg
1801cc to 2000cc	1050kg	1000kg
2001cc to 2500cc	1120kg	1080kg
2501cc to 3000cc	1170kg	1140kg
3001cc to 3500cc	1260kg	1230kg
3501cc to 4000cc	1320kg	1310kg
4001cc to 4500cc	1400kg	1400kg
4501cc to 5100cc	1500kg	1500kg
Over 5100cc	1590kg	1590kg

This is the real weight of the car, without driver nor co-driver nor their equipment, including the crew's helmets. Headphones external to the crew's helmets may be left in the car during weighing.

The weight of the car may be checked with the crew on board (driver plus co-driver plus their full equipment). In this case the minimum weight shall be as specified above, plus 160kg.

The capacity ranges are set for the purpose of determining minimum weight only and are inclusive of the relevant rotary and supercharging corrective factors with the exception that the supercharging factor shall not apply to an Option 3 engine with a 30mm restrictor (refer Article 300-1), which shall instead be required to comply with the 1801cc to 2000cc minimum weight.

At no time during the event may a car weigh less than the minimum weight stated in this article, except where that would result in the car exceeding its Gross Vehicle Mass (GVM).

In such a case it is permitted to add sufficient ballast in order to meet the GVM when the car is fully fuelled and equipped ready for competition (+/- 10kg). It is the responsibility of the Competitor to provide proof of the correct GVM via the official workshop manual or other definitive manufacturer's documentation, otherwise the Group G2 minimum weight shall apply.

**Ballast:** Should ballast be required to be carried to meet the specified minimum weight, it shall be affixed to the rear floor space, inside the passenger compartment of the vehicle, in accordance with the following requirements:

1. Ballast must be secured such that tools are required for its removal and so as to allow the fixing of seals by the scrutineers.
2. It must be made from stacking steel plates according to the following drawing.
3. The plates must be firmly attached inside a housing with not fewer than five (5) M12 screws.
4. If attached directly to the floor, the floor must be reinforced under the head of each screw by a reinforcement plate which is at least 3mm thick and 2,500mm<sup>2</sup> area.
5. The housing containing the ballast plates must be sealed by a cover.
6. All nuts must be safety wired in place.

